

PK17784P

**VARI**

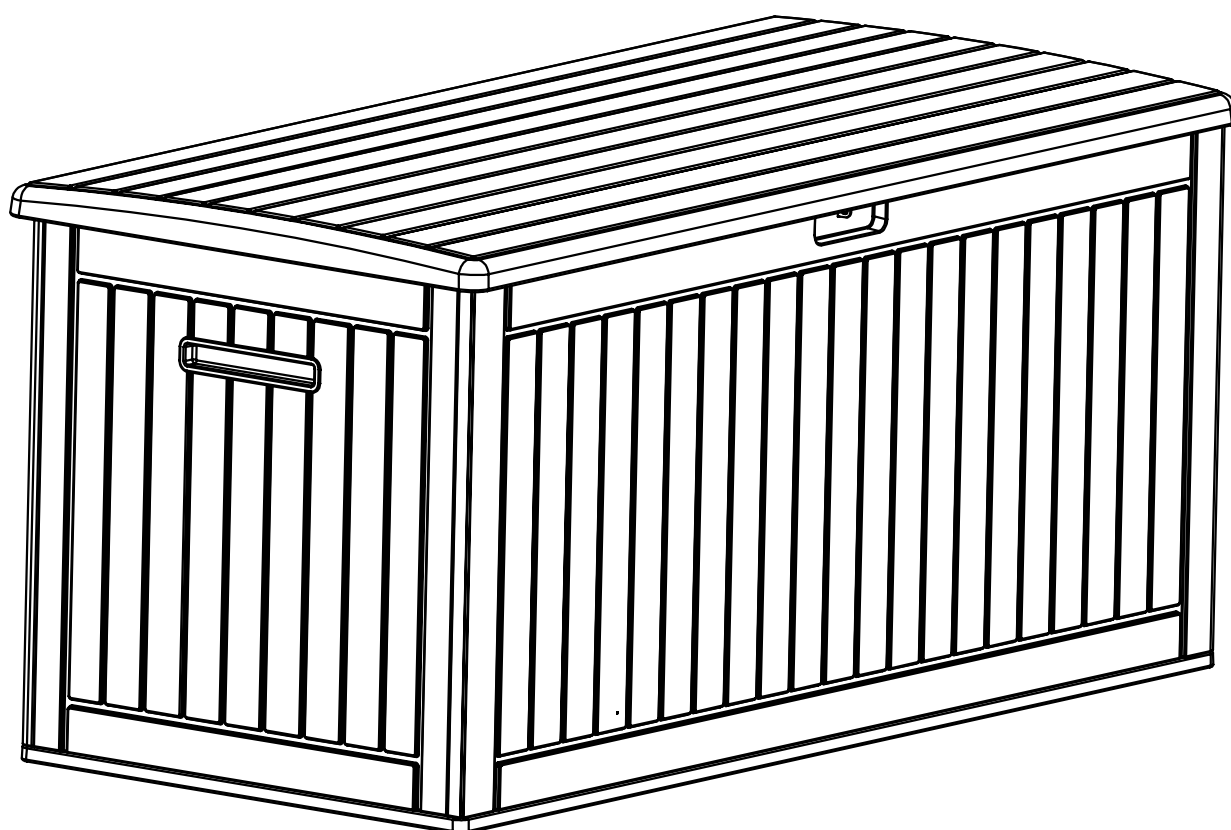

# PUTEKASSE 985L



**NO**





Monteringsanvisning

---

## DELER

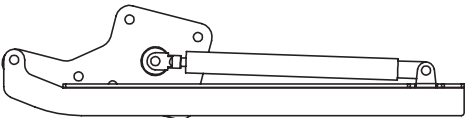
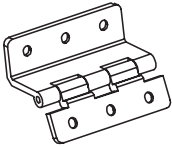
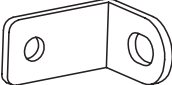
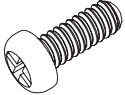
Pass på at alle deler og skruer er inkludert og at de er det uskadet før montering av produktet. Hvis enheten er skadet i transport, må enheten ikke monteres før du kontakter forhandleren.

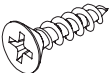
Skade på deler skal meldes til forhandleren før enheten monteres og tas i bruk. Vær oppmerksom på at noen deler kan være skjult i emballasjen som beskytter delene under transport. Hvis deler mangler, sjekk emballasjen nøye.

Nr	Beskrivelse	Bilde	Antall
1	Hydraulisk hengsel		2
2	Hengsel til lokk		3
3	Brakett hengelås		1
4	Skrue M6x12		7
5	Mutter M6		1
6	Skrue M5x12		18
7	Skrue M5x14		10
8	Gummifeste 65x30x3 (Følger med 4 stk. ekstra)		20

## DELOVERSIKT

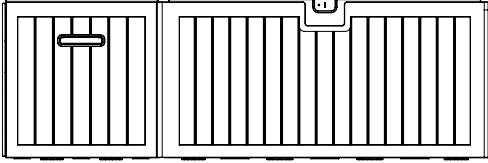
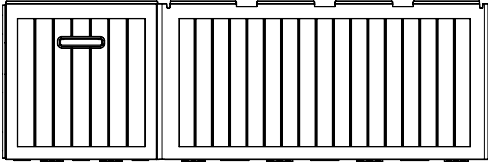
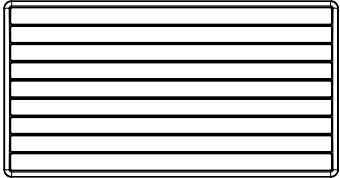
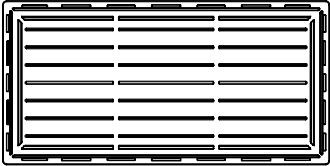
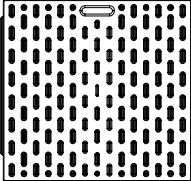
Nr	Beskrivelse	Bilde	Antall
A	Side og frontvegg		1
B	Side og bakvegg		1
C	Lokk		1
D	Bunn		1
E	Skillevegg		1

**ADVARSEL!**

IKKE BRUK ELEKTRISK VERKTØY FOR Å MONTERE MODULEN.

VERKTØY MED MASKINKRAFT KAN SKADE OVERFLATEBELEGGET PÅ SKRUER OG ØDELEGGE FESTENE TIL SKRUENE.

# MONTERING

LEGG ET STYKKE PAPP PÅ GULVET (F.EKS ESKEN PRODUKTET ER PAKKET I) FOR Å UNNGÅ RIPER PÅ DELENE UNDER MONTERING.

- 1** Monter sideveggene med bunnsiden opp, dette gjøres ved å løfte frontveggen (A) og entre hver ende i sporene som finnes i bakveggen (B). Skyv delene sammen. Dette kan være enklere å gjennomføre dersom man er to personer.

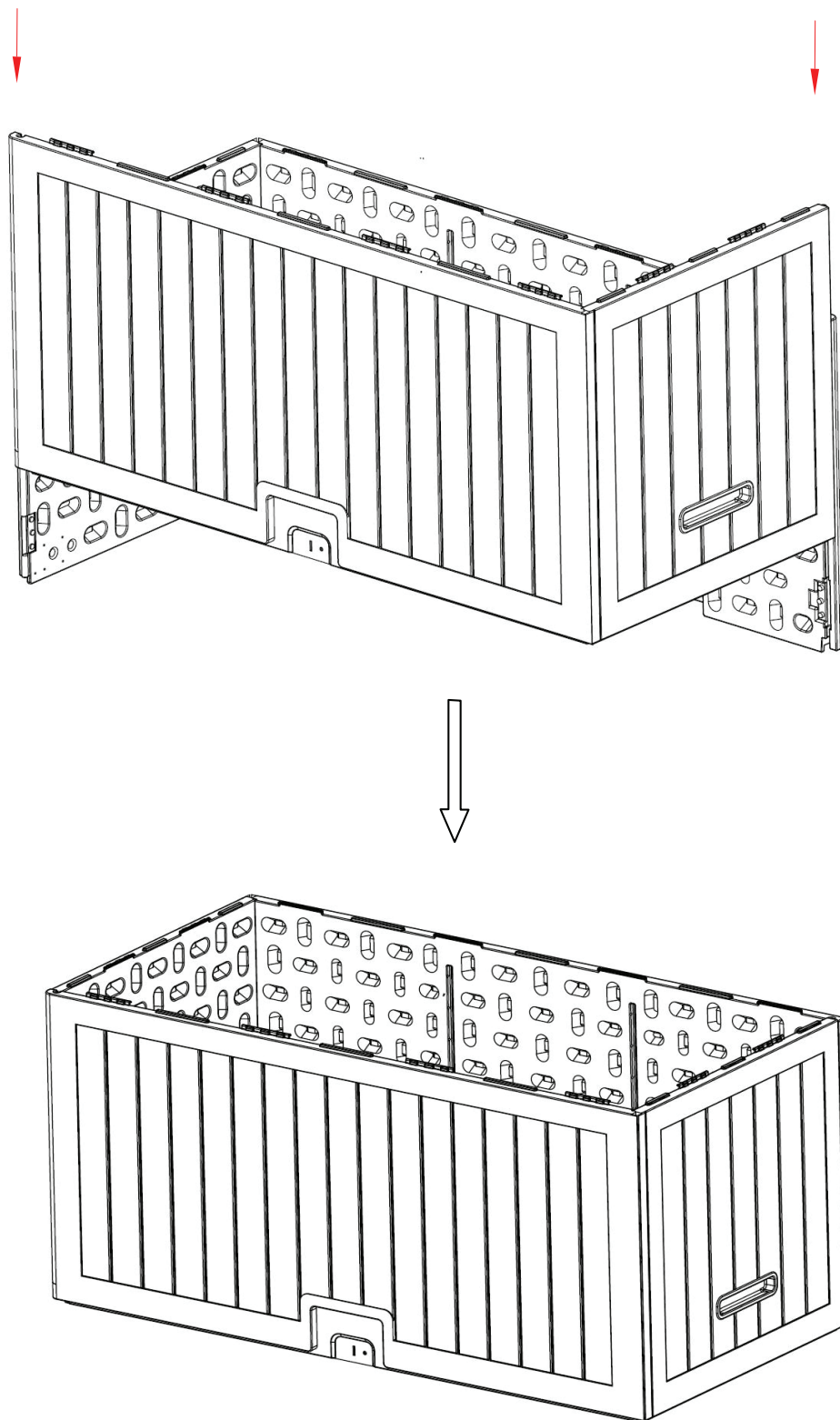

## MONTERING

- 2** Snu de sammensatte veggene og tilpass bunnen til veggene. Press bunnplaten ned på veggene. Legg press på de opphøyde sporene i veggene. Da vil den gi et klikk når den er på plass, for enklere montering kan man bruke en gummihammer. **OBS!** For harde slag kan skade/ sprekke bunnplaten.

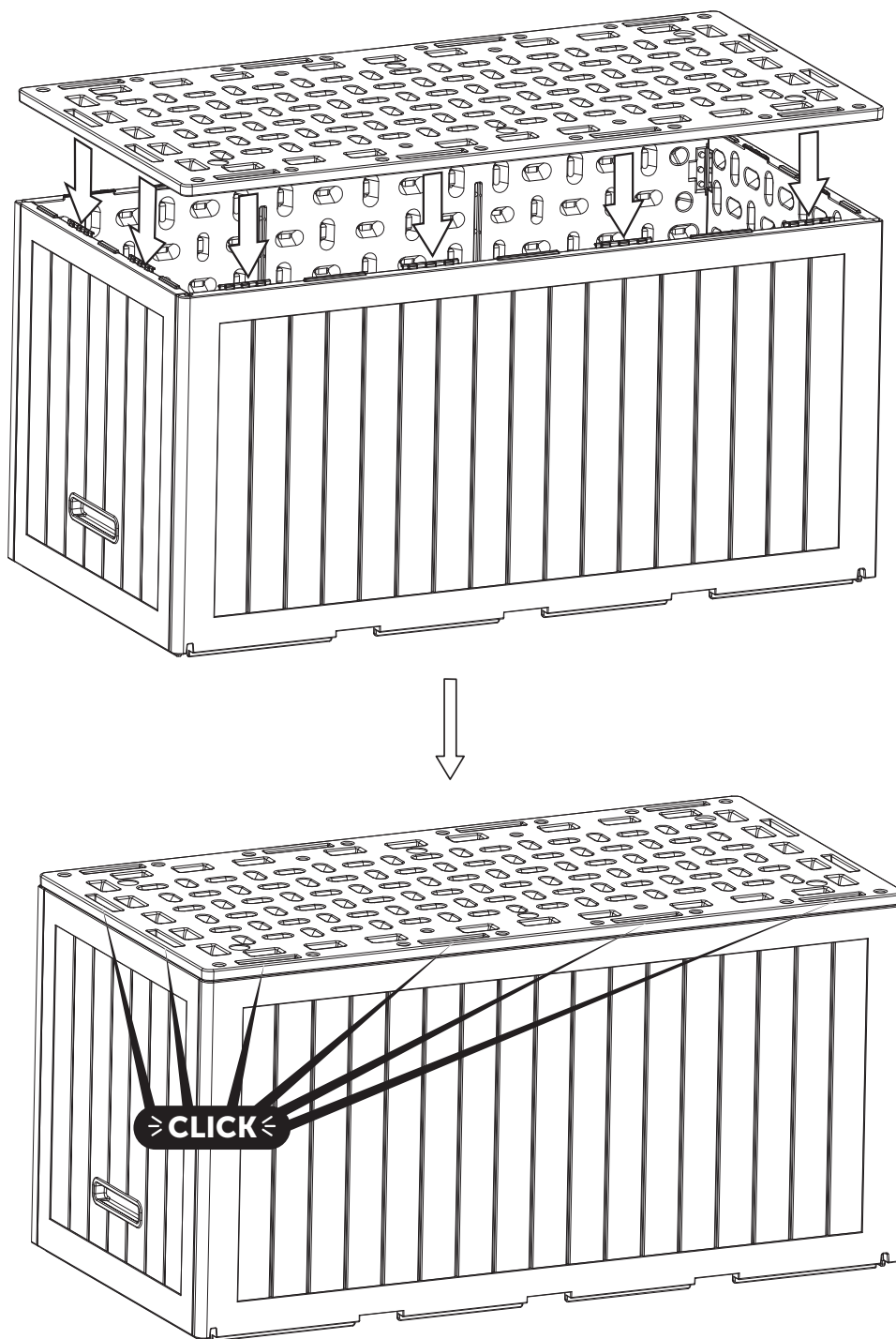

## MONTERING

- 3** 1. Skyv inn skillevegg i det sporet du ønsker. Det er valgfritt om du vil montere denne.  
2. Entre skruene til hydraulikkpumpene på hver side med 10 stk. skruer (M5x14) og stram til.  
3. Monter hengslene for lokket med 9 stk. skruer (M5x12).

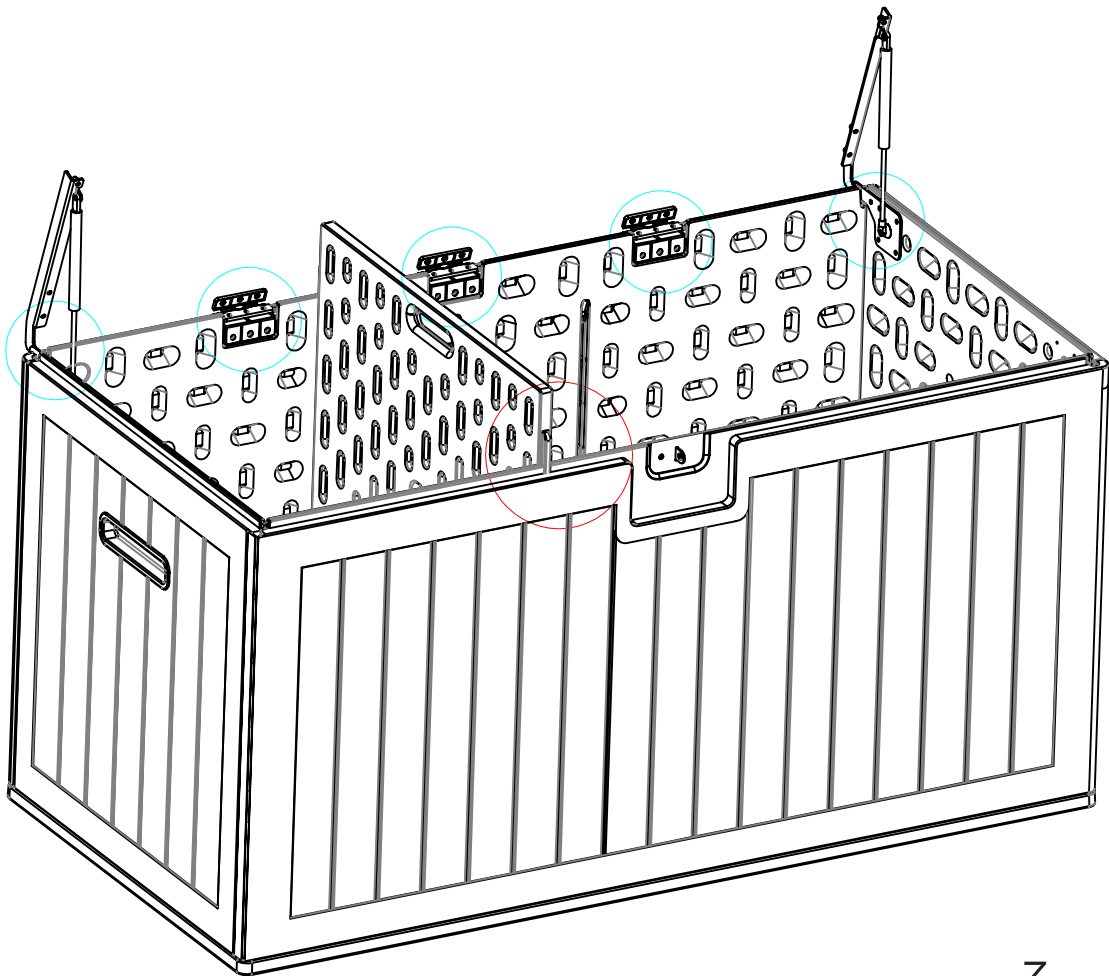

1

2

3

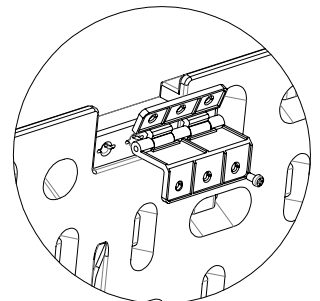
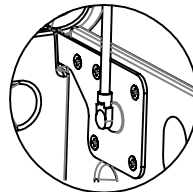
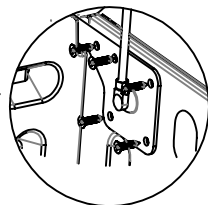
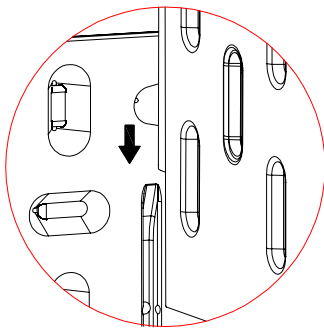

## MONTERING

**4** Monter på lokket.  
Det kan være en fordel å være to personer for enklere montering.

Skru lokket i hengslene på bakveggen med 9 stk. skruer (M5x12).

Skru fast hydraulikk pumpene i lokket med 6 stk. skruer (M6x12).

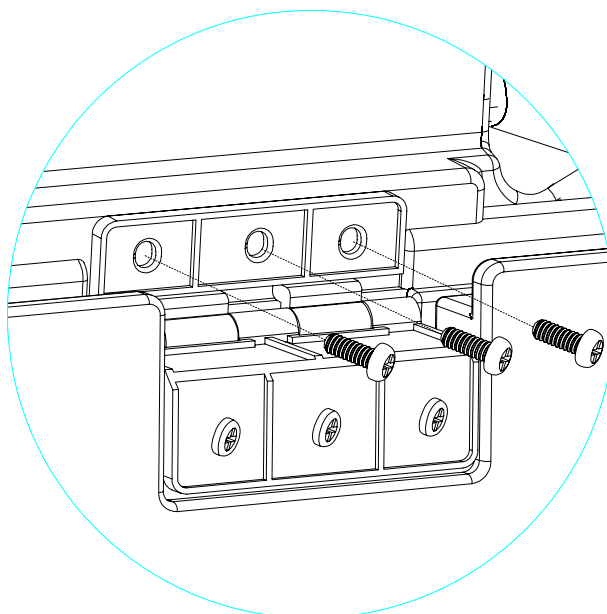
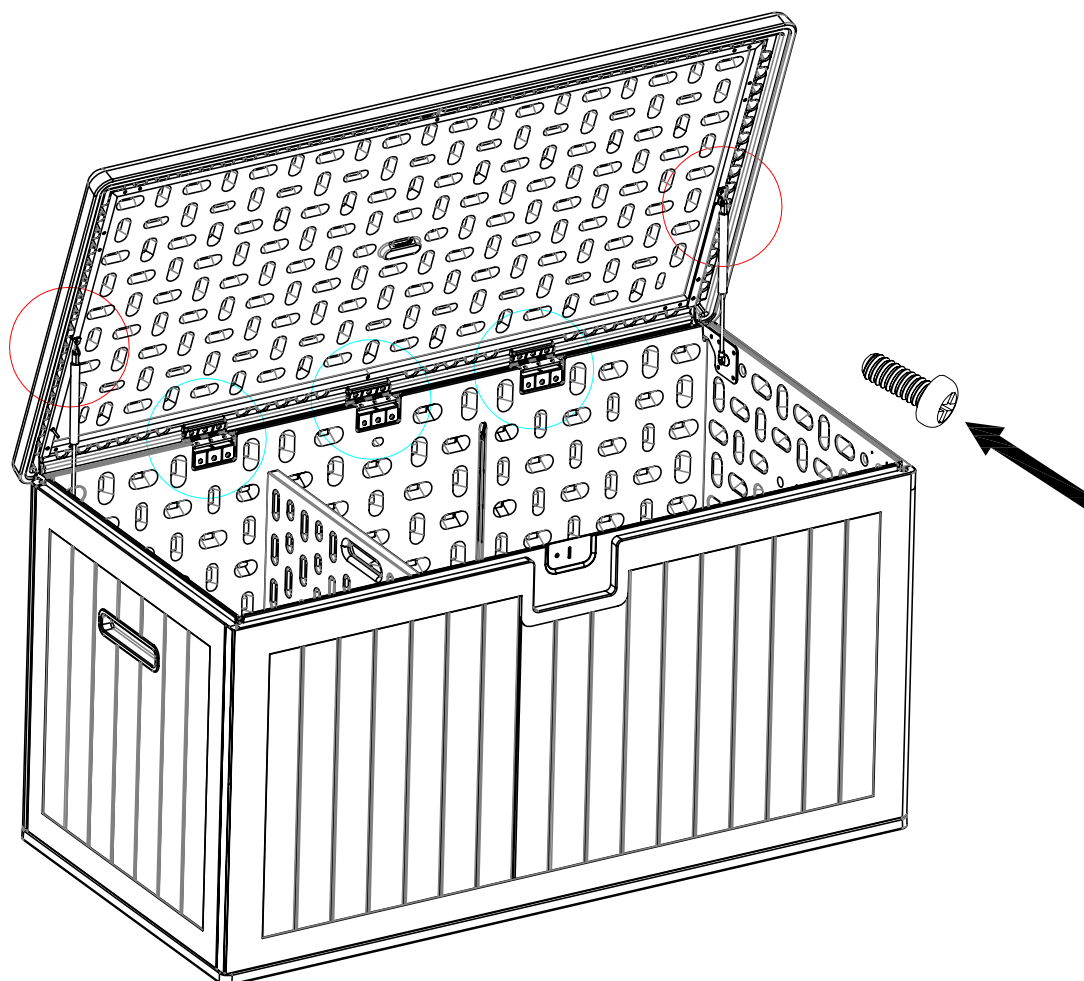

## MONTERING

- 5** Sett inn braketten for hengelås (3) i slissen fra baksiden og fest den med 1 stk. skrue (M6x12) og en mutter M6.

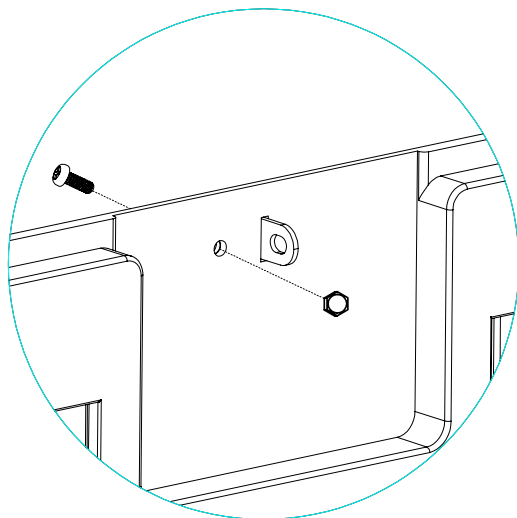
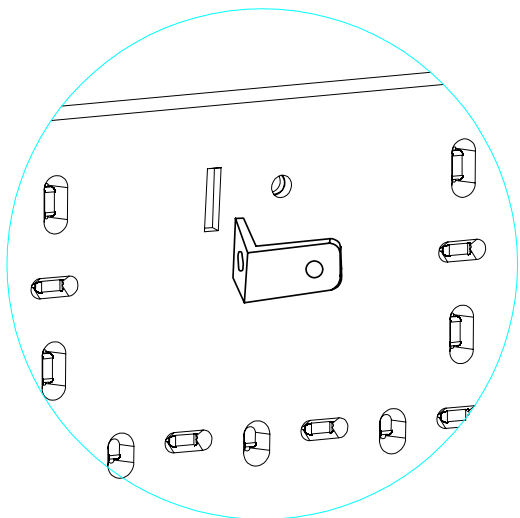
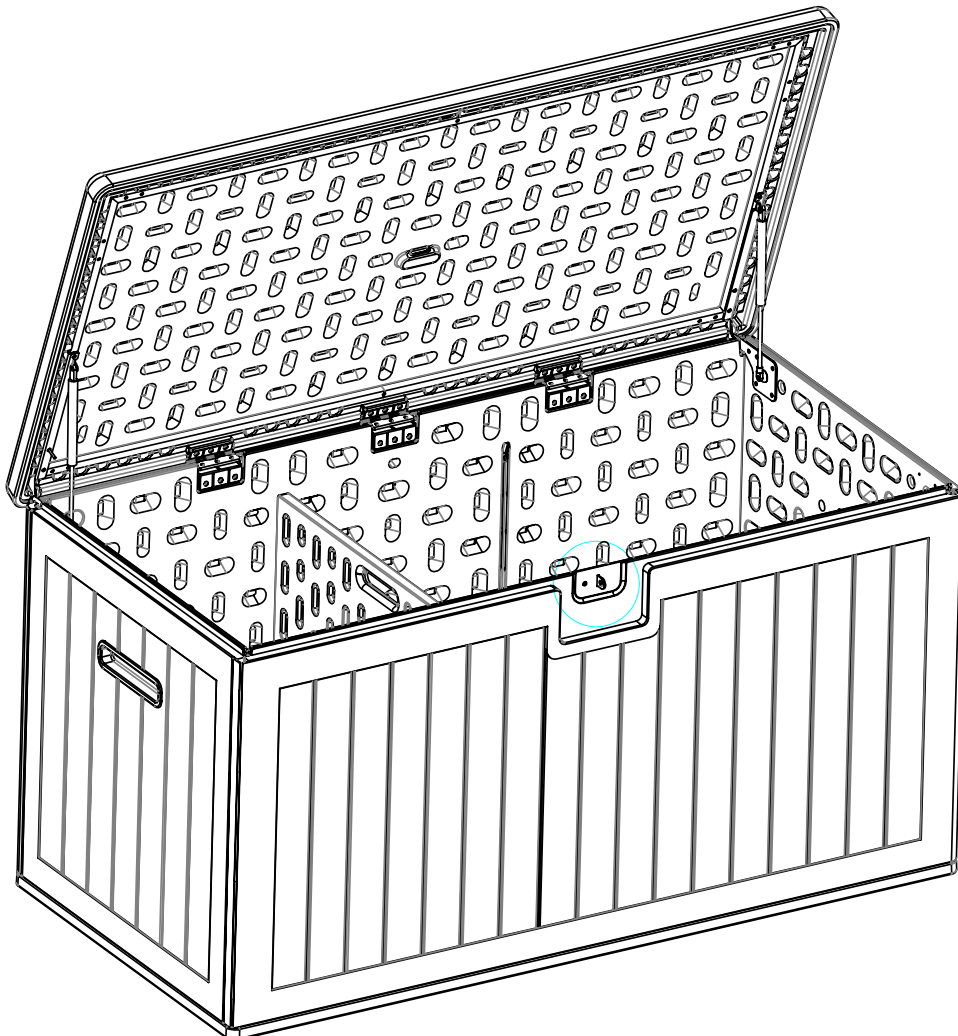

---

## MONTERING

- 6** Fjern dobbeltsidig teip på gummifester 20 stk. og plasser de på bunnpanelets uthvede områder.

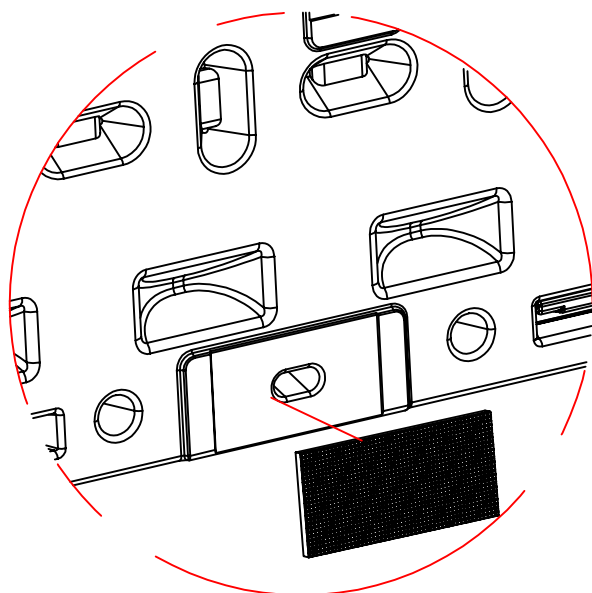
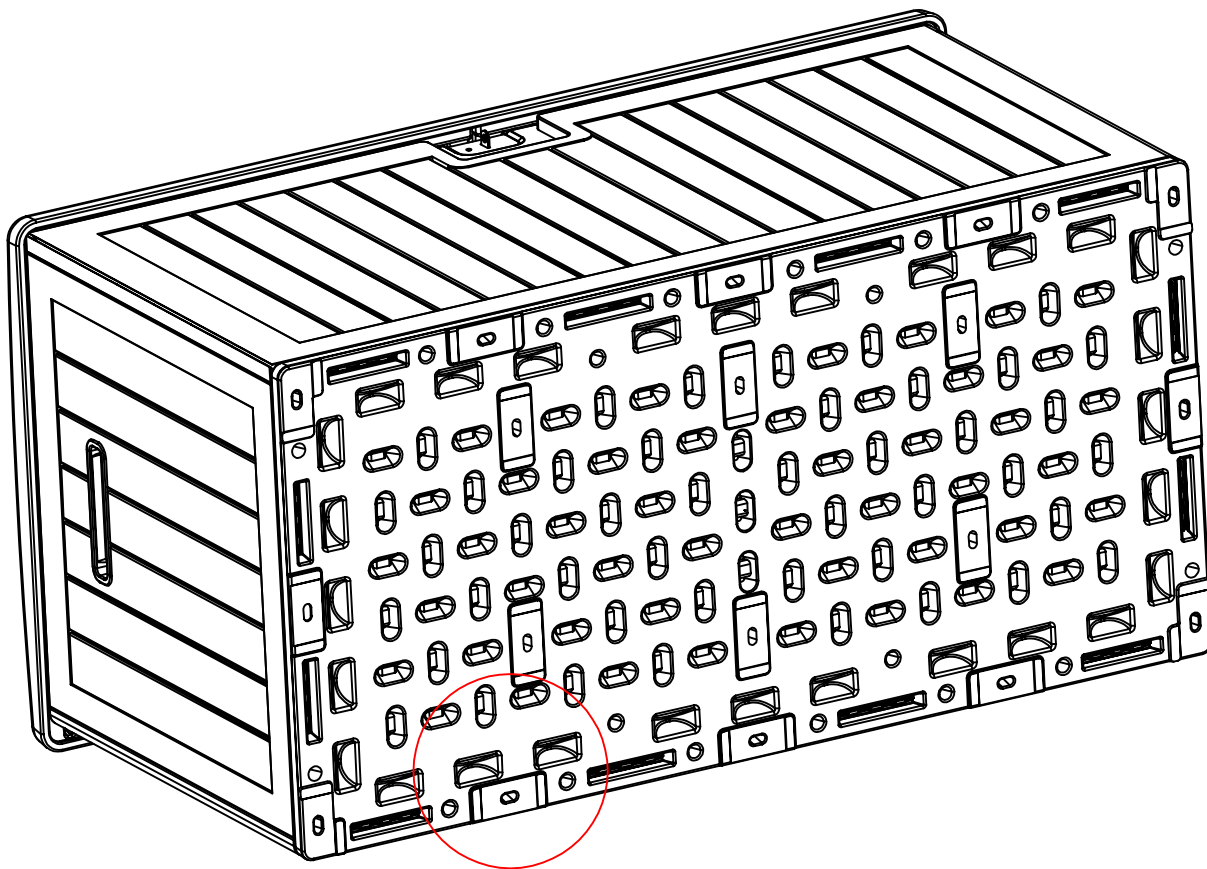

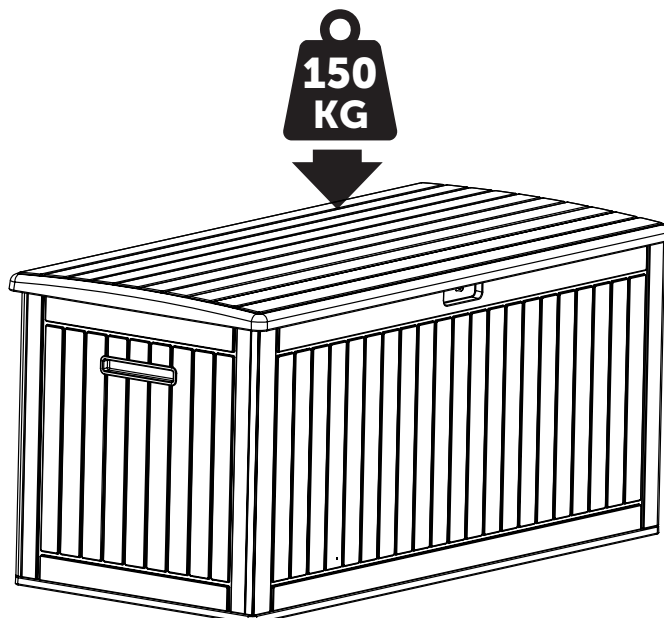

Max vekt: 150 kg

## ADVARSLER

- **Drenering:** Påse at vann ikke samler seg i bunnen eller rammeverket. Stillestående vann kan føre til frostspreng ved kulde. Dette dekkes ikke av reklamasjon.
- **Vedlikehold:** Jevnlig rengjøring forlenger levetiden og forebygger skader. Bruk mildt såpevann og myk klut. Unngå sterke rengjøringsmidler som kan påvirke plasten.
- **Ytre påvirkning:** Salt, fugleskitt og luftforurensning kan med tiden skade plastoverflater. Regelmessig rengjøring anbefales for å bevare utseende og funksjon.
- **Vekt og belastning:** Overskrid ikke oppgitt maksimal belastning. Overbelastning kan skade konstruksjonen og medføre at skjøter eller fester løsner. Dette dekkes ikke av reklamasjon.
- **Snø og is:** Fjern snø og is som legger seg oppå lokket. Tyngden kan deformere eller skade konstruksjonen over tid.
- **Montering:** Bruk kun håndverktøy. Elektroverktøy kan skade plastdelene og føre til at muttere løsner eller gjenger ødelegges.
- **PUTEKASSEN ER IKKE ET LEKETØY, LA ALDRI BARN LEKE PÅ ELLER INNI PUTEKASSEN.**
- **DETTE PRODUKTET ER BEREGNET FOR BRUK I PRIVATE HUSHOLDNINGER OG ER IKKE EGNET FOR PROFESJONELL BRUK.**

---

## VEDLIKEHOLD

- Vi anbefaler at putekassen låses.
- Lås er ikke inkludert.
- Etter regnvær anbefales det å tørke av putekassen med en klut før man åpner lokket for å forhindre at vann ev. drypper ned i putekassen.
- Brannfarlig væsker skal ikke oppbevares i putekassen.
- Påse regelmessig rengjøring av møbelet med mildt såpevann og myk børste eller svamp. Blir møbelet utsatt for mye sur nedbør, forurensning, fugleskitt og lignende kan det etse på overflatebehandlingen og skape stygge merker. Skyll av ved å sprute med hageslange. Ikke bruk høytrykksspyler, da dette kan skade møblene og overflatebelegget.
- Unngå skuremidler da dette kan ripe opp platen. Vask med mildt såpevann eller et egnet plastvaskemiddel. Skyll godt med rent vann etter vask.
- Plasser under tak hvis mulig, eller på et sted som skjermer mot kraftig regn og direkte sollys.
- Påfør gjerne et UV-beskyttende middel for plast (fås kjøpt på byggevarehus) for å forhindre falming og sprekkdannelse.
- Unngå stående vann på lokket – det kan deformere platen over tid.
- Sjekk hengsler og låser jevnlig – stram eventuelle skruer som løsner.
- Smør bevegelige deler med silikon- eller teflonspray for smidig åpning og lukking.
- Unngå overbelastning – ikke fyll mer enn produsentens anbefaling.
- Tøm og oppbevar putekassen frostfritt om vinteren.

## OPPBEVARING & LAGRING

- Rengjør møblene før du pakker de bort og sørg for å gi de ekstra beskyttelse. Bruk egnede rengjøringsprodukter og tørk over til slutt med en fuktig klut.
- Sørg for at møblene er tørre og ikke oppvarmet før de lagres under møbeltrekk. Gjøres ikke dette kan det skapes reaksjon med trekket, som resulterer i flekker og skjemmer utseendet på møblene. Er det fuktighet i møblene kan dette skape frostspreng i rammen eller skjøter. Dette kan utvide seg og skade strukturen hvis det dannes is. Sjekk at det ikke er vann i rammen før lagring, dette må ev. dreneres i dreneringshullene.
- Vinterlagres møblene under et overtrekk må du sørge for god ventilasjon.
- Møblene må lagres riktig vei opp slik at vann ikke kan trenge inn i rammeverket.
- Vær oppmerksom på at skader som oppstår på grunn av feil lagring og/eller frostspreng ikke dekkes av reklamasjon.
- Vi anbefaler på det sterkeste å oppbevare puter og andre tekstiler innendørs om vinteren.  
**IKKE BRUK PUTEKASSEN TIL LANGTIDSOPPBEVARING AV TEKSTILER/PUTER.**



## REKLAMASJONSRETT

Dette produktet er dekket med reklamasjonsrett i henhold til forbrukerlovgivningen. Produktet gjennomgår streng kvalitetskontroll og testing på fabrikk. Skulle det mot formodning mangle deler i pakken eller produktet være skadet, ta kontakt med forhandler eller nedenstående forbrukerkontakt for videre hjelp.

Ved skader på produktet ber vi om at bilder av skaden og produktets emballasje vedlegges reklamasjonen.

Defekter som skyldes feilbruk, manglende vedlikehold eller modifikasjon av produktet, medfører bortfall av reklamasjonsretten.

Ødelagte deler som ikke skyldes reklamasjon, faktureres etter gjeldene prisliste+frakt og ekspedisjonsgebyr.

Ved behov for deler eller ved reklamasjon, ta kontakt med forhandler eller forbrukerkontakt.

**Forbrukerkontakt:**

**Nordic Season Products AS**

Kjeller Vest 3

2007 Kjeller, Norge

E-post: [support@nordicseason.no](mailto:support@nordicseason.no)

Tlf: 0047 924 78 600 (10–14 man–fre)

[www.nordicseason.no](http://www.nordicseason.no)

Ved reklamasjon på produktet skal kjøpsbevis vedlegges

Produsert i Kina for Nordic Season Asia Co., Ltd.



# CUSHION BOX

## 985L

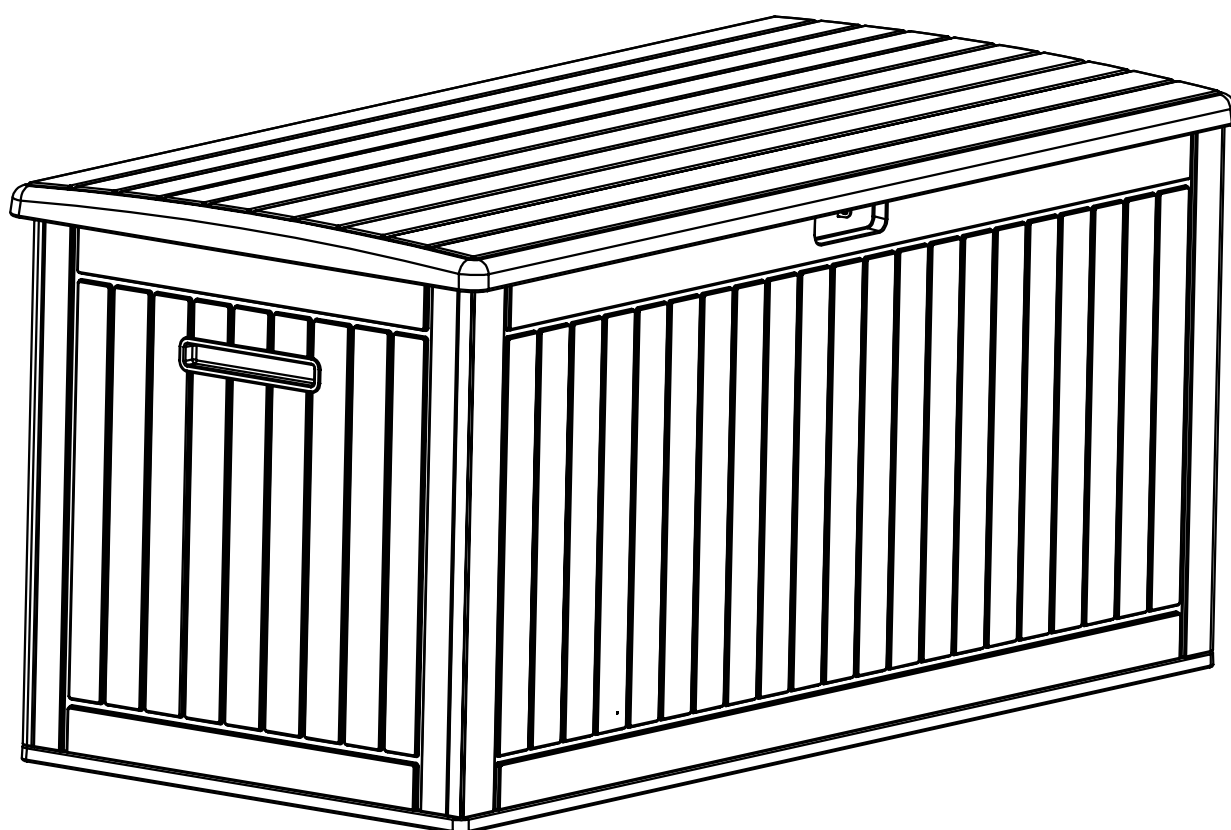





EN

Assembly instructions

## PARTS LIST

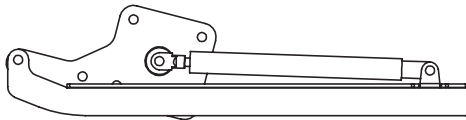
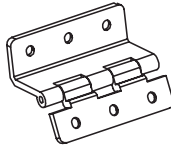
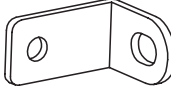
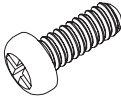
Make sure all parts and screws are included and that they are undamaged before assembling the product. If the unit is damaged in transport, the unit must not be assembled before contacting the dealer.

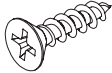
Damaged parts or damage on the paint caused by transport, must be reported to the dealer before the unit is assembled and put into use. Please note that some parts may be hidden in the styrofoam to protect the part in transport. If parts are missing, check the packaging carefully.

No	Description	Image	Qty
1	Hydraulic hinge		2
2	Lid hinge		3
3	Padlock bracket		1
4	M6x12 screw		7
5	M6 nut		1
6	M5x12 screw		18
7	M5x14 screw		10
8	Rubber sticker 65x30x3		20

## PARTS

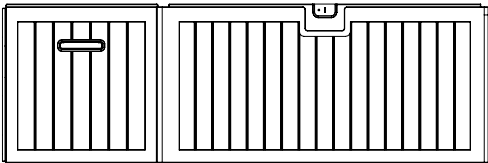
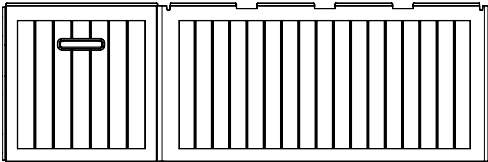
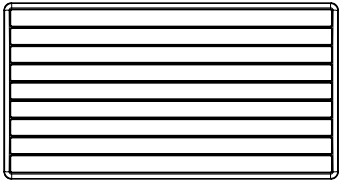
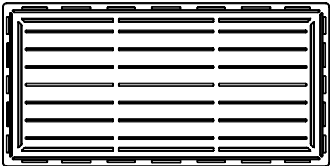
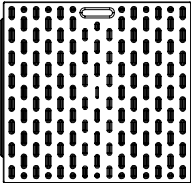
No	Description	Image	Qty
A	Side og front wall		1
B	Side og back wall		1
C	Lid		1
D	Bottom		1
E	Partition wall		1

**WARNING!**

**DO NOT USE ELECTRICAL TOOLS TO ASSEMBLE THE FURNITURE.**

**TOOLS WITH EXCESSIVE FORCE MAY DAMAGE THE SURFACE COATING OF SCREWS AND RUIN THE FASTENERS OF THE SCREWS.**

## ASSEMBLY

PLACE A PIECE OF CARDBOARD ON THE FLOOR (E.G THE OUTER CARTON) TO PREVENT SCRATCHING THE UNIT AND PARTS DURING ASSEMBLY.

- 1** Assemble the side walls with the bottom side facing up, this is done by lifting the front wall (A) and inserting each end into the slots located in the back wall (B). Slide the parts together. This step may be easier with two people.

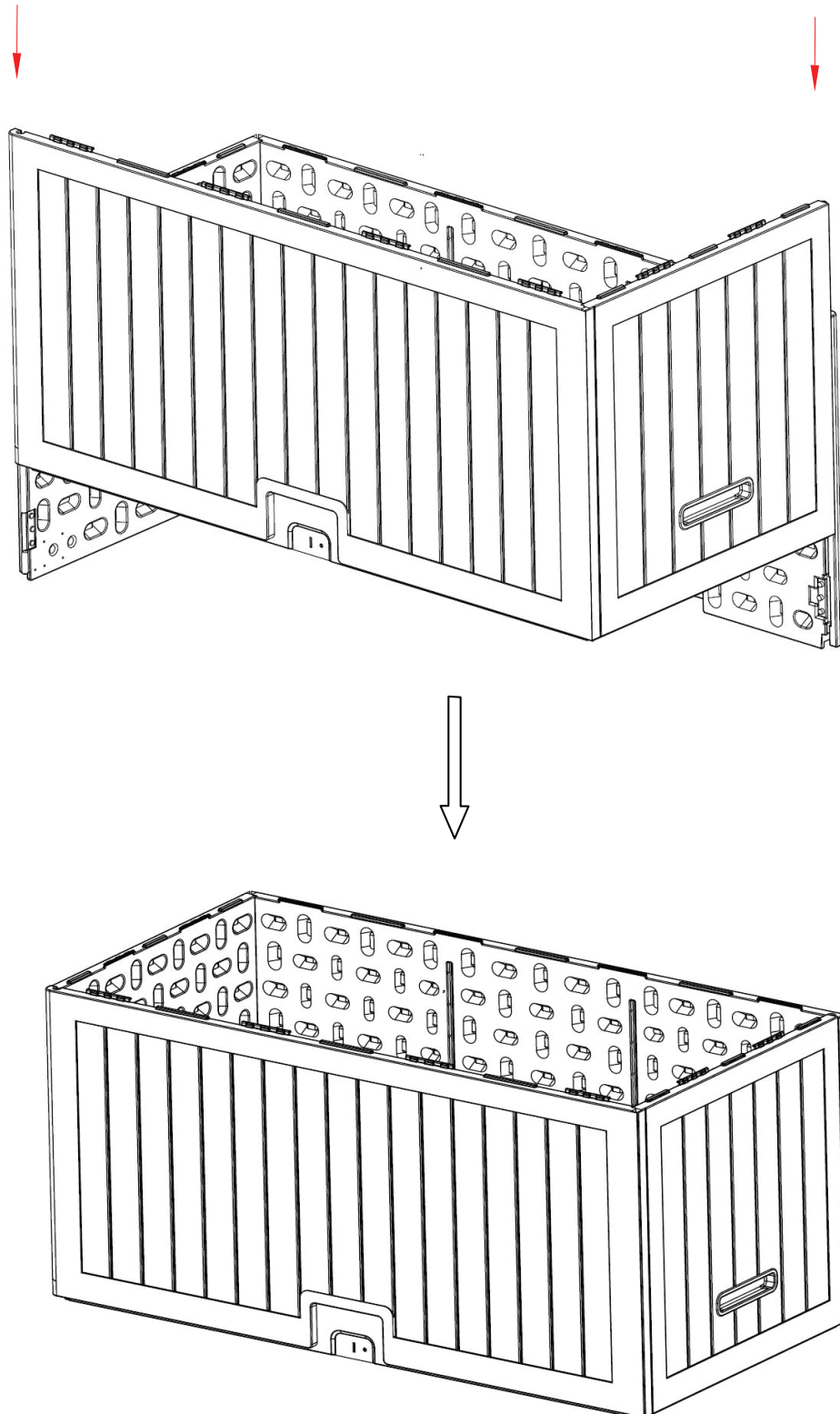

## ASSEMBLY

- 2** Turn the assembled walls upside down and align the bottom panel with the walls. Press the bottom panel down onto the walls, applying pressure on the raised slots in the walls. It will click into place when properly seated. For easier assembly, a rubber mallet can be used.

**Note:** Excessive force may damage or crack the bottom panel.

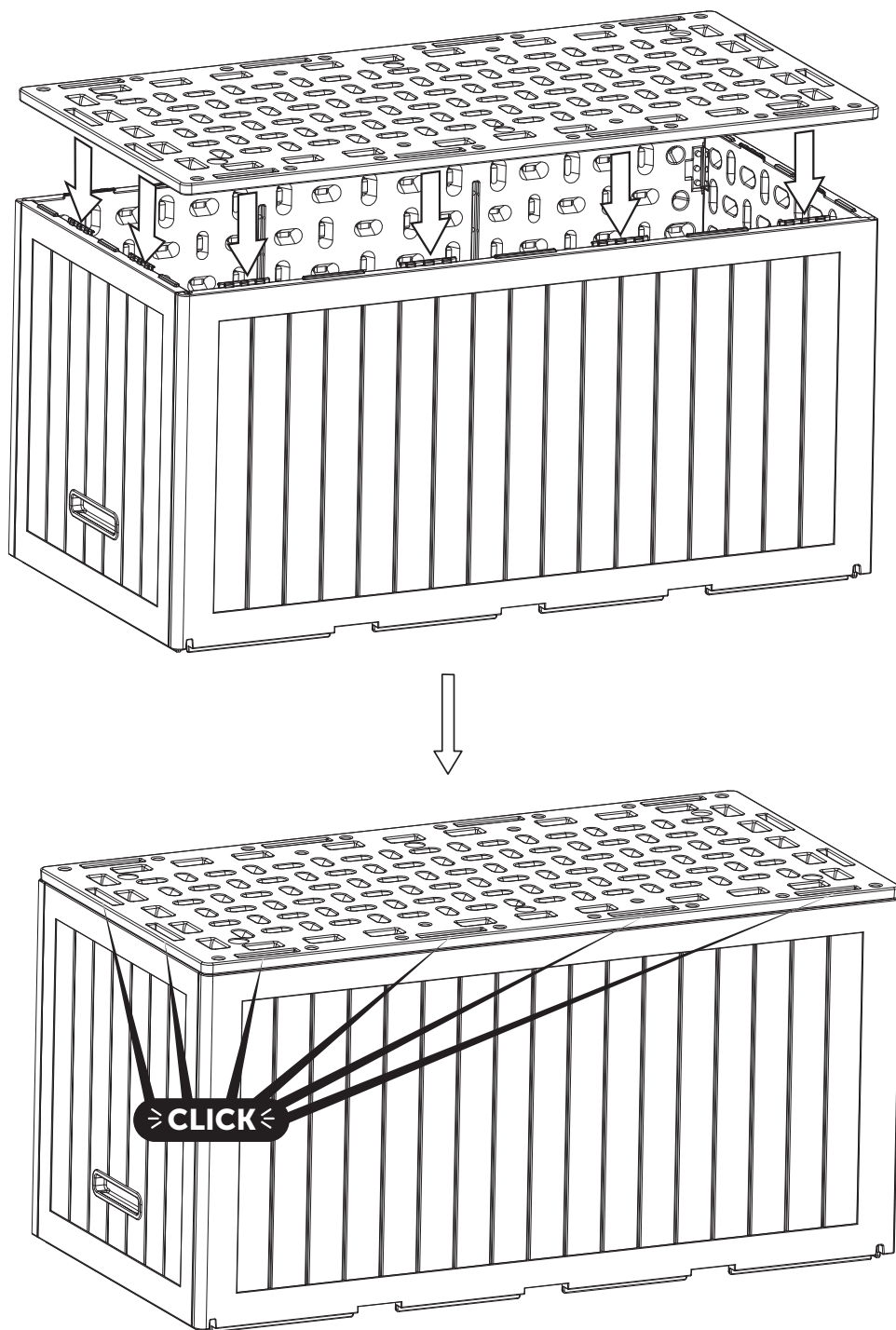

---

## ASSEMBLY

- 3**
1. Slide the divider into the desired slot. It is optional whether you want to install this.
  2. Insert the screws for the hydraulic pumps on each side using 10 screws (M5x14) and tighten.
  3. Install the lid hinges using 9 screws (M5x12).

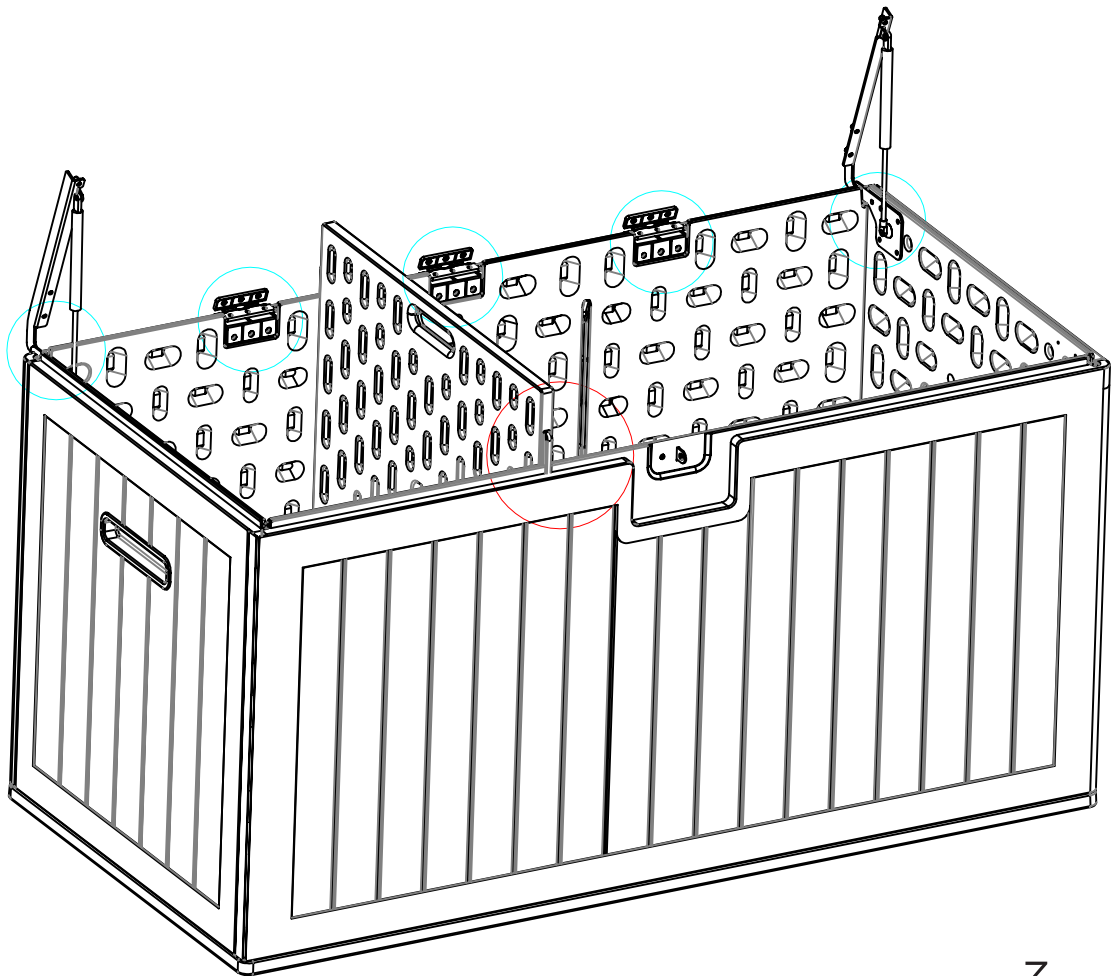

1

2

3

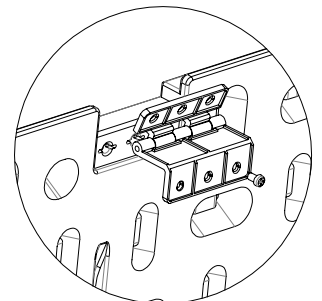
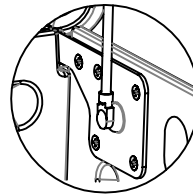
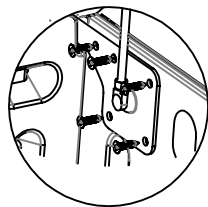
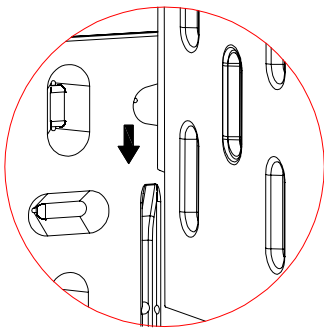

## ASSEMBLY

- 4** Attach the lid.  
It may be helpful to be two people for easier assembly.

Screw the lid to the hinges on the back wall using 9 screws (M5x12).

Secure the hydraulic pumps to the lid using 6 screws (M6x12).

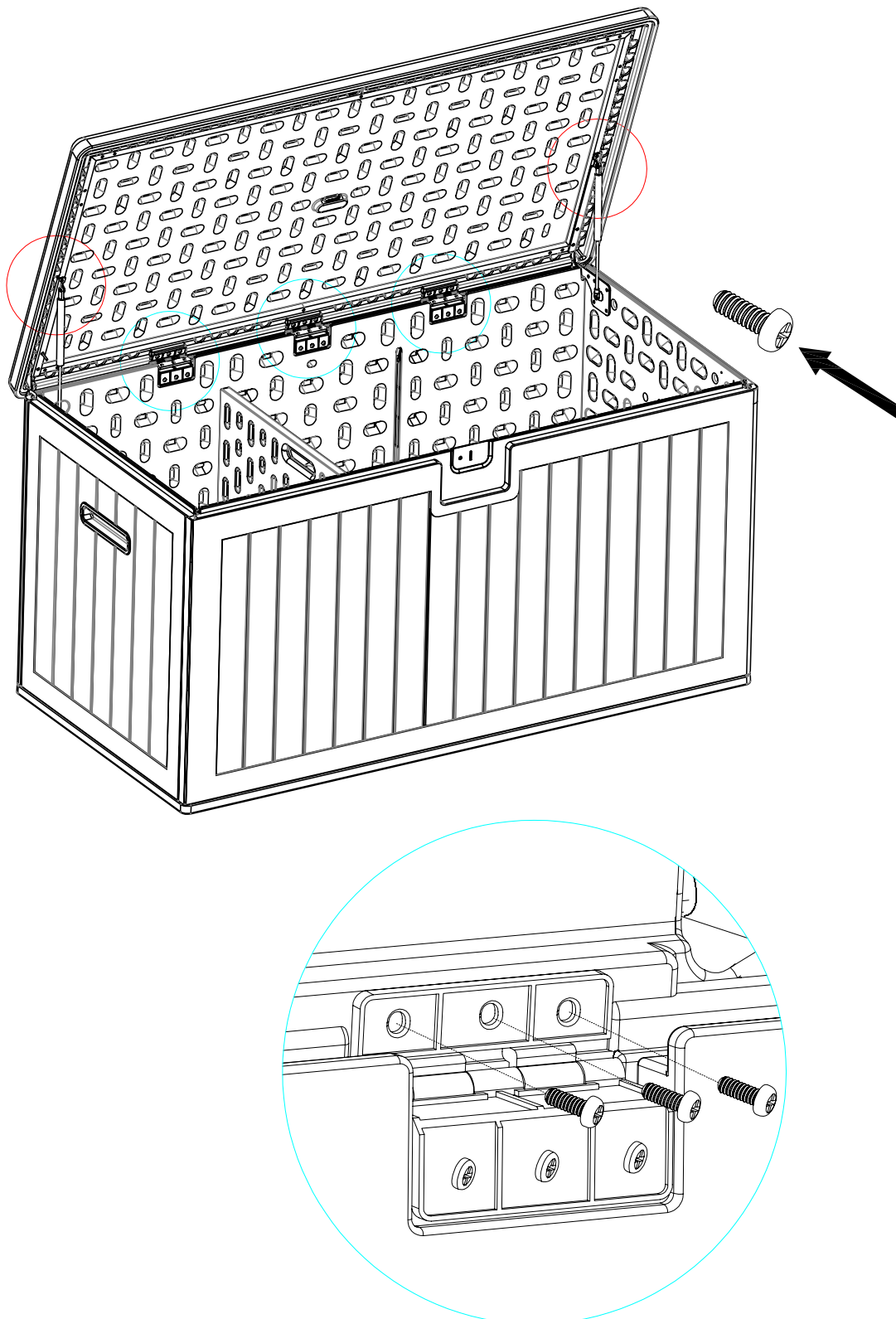

---

## ASSEMBLY

- 5** Insert the locking bracket (3) into the slot from the back and secure it with 1 screw (M6x12) and one M6 nut.

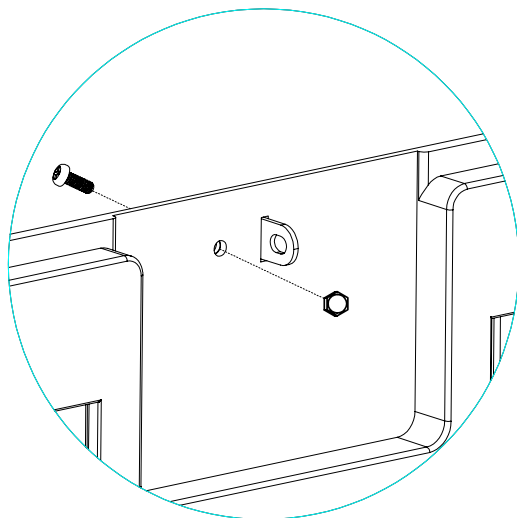
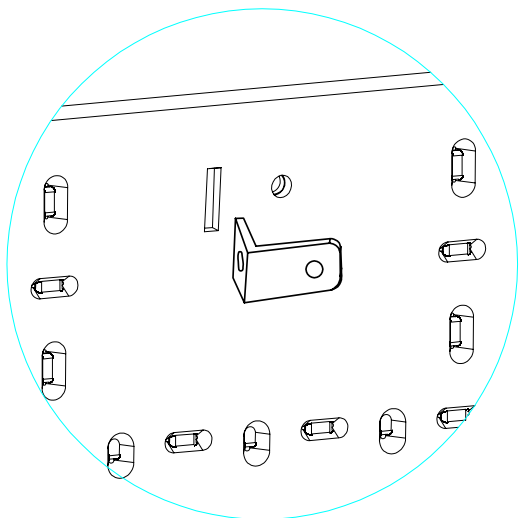
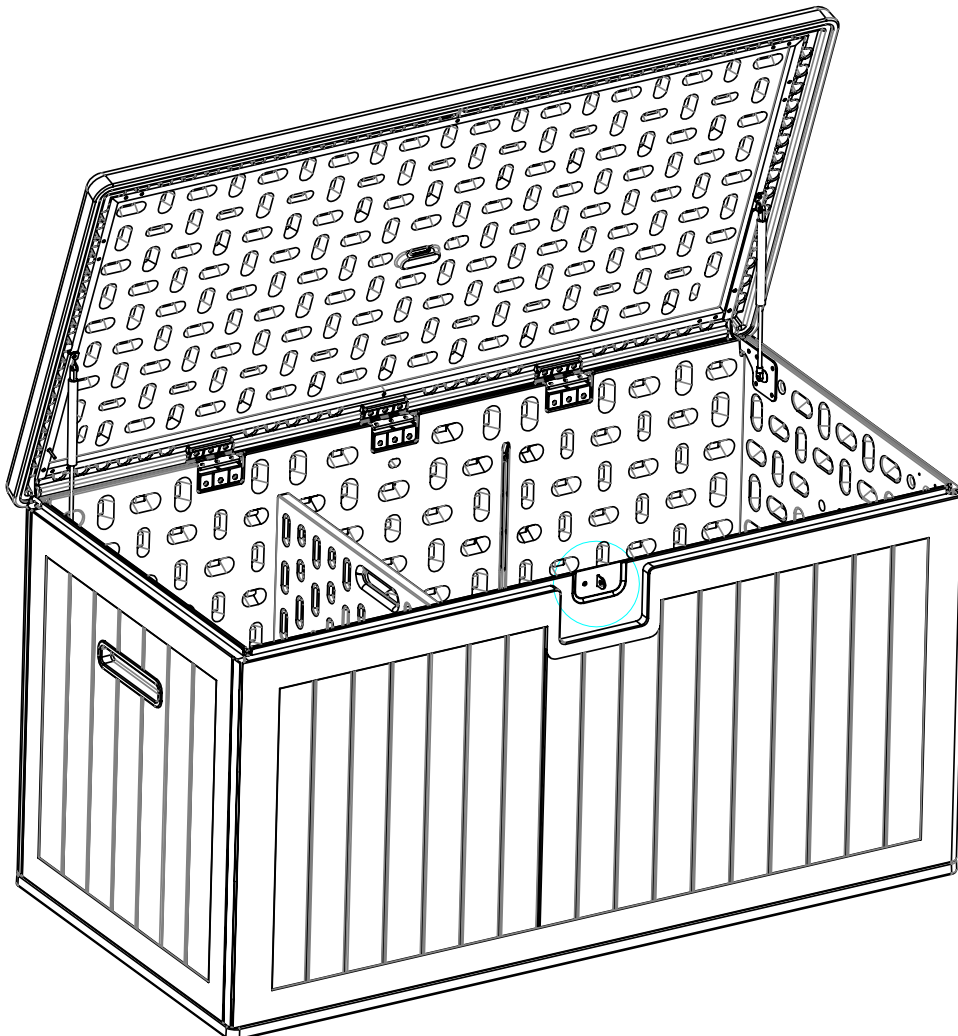

## ASSEMBLY

- 6** Remove the double-sided tape from the rubber stickers 20 pcs and place them on the raised areas of the bottom panel.

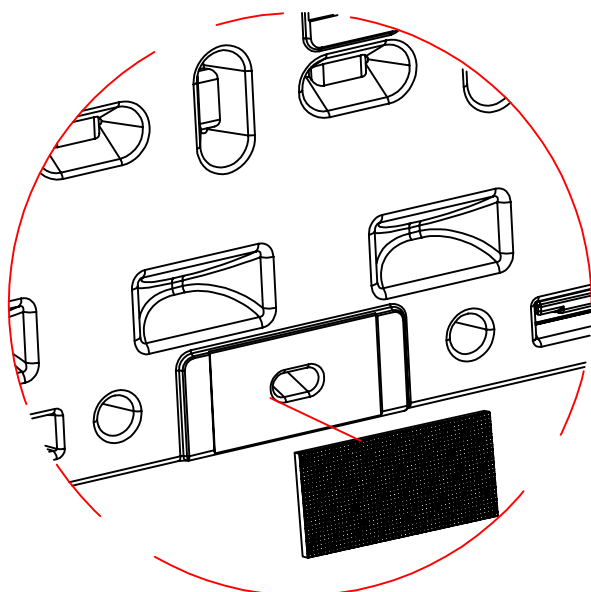
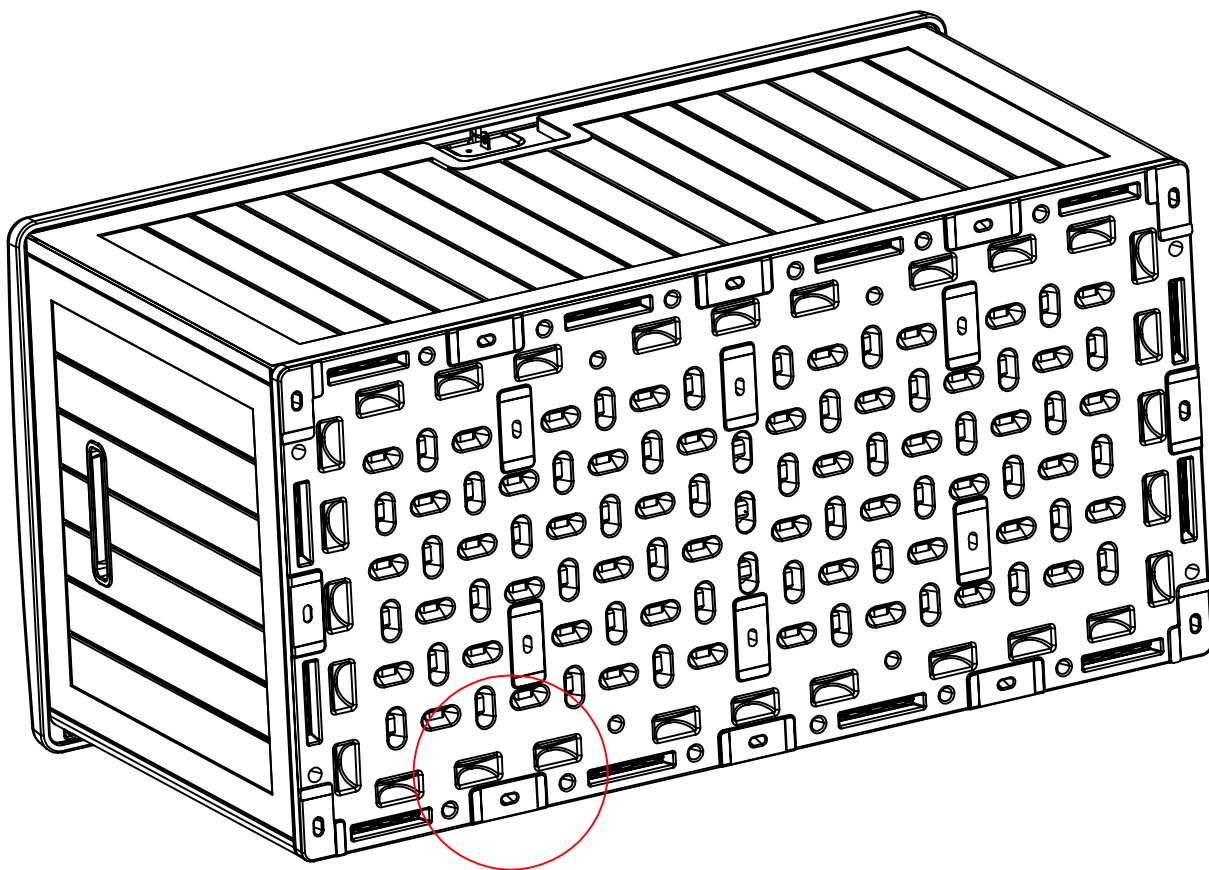

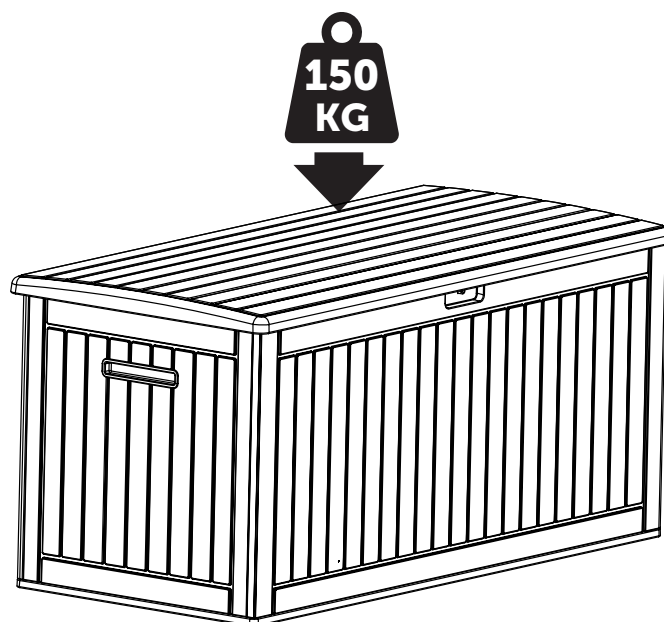

Max load: 150 kg

## WARNING!

- **Drainage:** Make sure water does not collect in the bottom or frame. Standing water may cause frost damage in cold conditions. This is not covered by warranty.
- **Maintenance:** Regular cleaning extends the product's lifespan and helps prevent damage. Use mild soapy water and a soft cloth. Avoid harsh cleaning agents that may affect the plastic.
- **External exposure:** Salt, bird droppings, and air pollution may damage plastic surfaces over time. Regular cleaning is recommended to preserve appearance and functionality.
- **THIS PRODUCT IS DESIGNED FOR USE IN DOMESTIC HOUSEHOLDS AND IS NOT INTENDED FOR COMMERCIAL USE IN RESTAURANTS OR SIMILAR VENUES.**
- **Weight and load:** Do not exceed the stated maximum load. Overloading may damage the structure and cause joints or fastenings to come loose. This is not covered by warranty.
- **Snow and ice:** Remove any snow and ice that accumulates on the lid. The weight can deform or damage the structure over time.
- **Assembly:** Use only hand tools. Power tools may damage plastic components and cause nuts to loosen or threads to strip.
- **THE CUSHION BOX IS NOT A TOY. NEVER ALLOW CHILDREN TO PLAY ON OR INSIDE THE CUSHION BOX.**
- **Storage of textiles:** Do not use the storage box for long-term storage of cushions or textiles, especially during winter. Indoor storage is recommended in cold and damp weather.
- **We strongly recommend storing cushions and other textiles indoors during the winter. DO NOT USE THE STORAGE BOX FOR LONG-TERM STORAGE OF TEXTILES/CUSHIONS.**

---

## MAINTENANCE

- We recommend locking the cushion box.  
Lock not included.
- After rainfall, it is advisable to wipe off the cushion box with a cloth before opening the lid to prevent water from dripping inside.
- Flammable liquids must not be stored in the cushion box.
- Clean the furniture regularly using mild soapy water and a soft brush or sponge. If the furniture is exposed to acid rain, pollution, bird droppings, or similar substances, it may cause etching on the surface and result in visible marks. Rinse off using a garden hose. Do not use a pressure washer, as this may damage the furniture and its surface coating.
- Avoid abrasive cleaners, as these may scratch the plastic. Wash with mild soapy water or a suitable plastic cleaner. Rinse thoroughly with clean water after washing.
- If possible, place the product under cover or in a location protected from heavy rain and direct sunlight.
- Applying a UV-protective product for plastic (available at hardware stores) is recommended to prevent fading and cracking.
- Avoid standing water on the lid – it may deform the plastic over time.
- Check hinges and locks regularly – tighten any loose screws.
- Lubricate moving parts with silicone or Teflon spray to ensure smooth opening and closing.
- Avoid overloading – do not exceed the manufacturer’s recommended capacity.
- Empty and store the cushion box in a frost-free environment during winter.

## SHORT AND LONG-TERM STORAGE

- Clean the module before storing and make sure to provide it with extra protection. Use suitable cleaning products and wipe it down with a damp cloth.
- Make sure that the module is dry and not heated before storing under a module cover. Moisture under the cover may create a reaction with the cover, or leave stains or undesirable marks on the module. Moisture on the module, also may cause frost damage to the frame or joints. Water turned to ice will expand and damage the structure if ice forms. Ensure that there is no water in the frame before storage. If present, any water must be drained using the drainage holes.
- If you are storing the module in a cover during the winter, ensure proper ventilation.
- The module must be stored right side up to prevent water from entering the frame.
- Please note that damage caused by improper storage and/or frost damage will not be covered by warranty.
- If the module is stored outdoors all year, make sure that water is drained from the module and not left standing with water in the frame. This can cause frost damage and will not be covered by warranty.
- We strongly recommend storing cushions and other textiles indoors during winter.  
**DO NOT USE THE BOX FOR LONG-TERM STORING OF TEXTILES/CUSHIONS.**



## WARRANTY CLAIM

This product is covered by a warranty in accordance with consumer legislation. It has undergone strict quality controls and testing at the factory. If there are any parts missing or the product has been damaged, please contact your dealer or the consumer contact below for help.

In the event of damage to the product, we ask for pictures of the damage and damage to the product's packaging is attached to the complaint.

Faults due to misuse, lack of maintenance or modification of the product will invalidate the warranty.

Damaged parts not due to a fault with the product will be invoiced according to our price list + carriage and administration fee.

If new parts are needed or in the event of a warranty claim, please contact your dealer or consumer contact.

Consumer contact:

### **Nordic Season Products AS**

Kjeller Vest 3

2007 Kjeller, Norge

e-mail: [support@nordicseason.no](mailto:support@nordicseason.no)

tlf: 0047 924 78 600 (10–14 mon–fri)

[www.nordicseason.no](http://www.nordicseason.no)

Always attach your receipt when making a warranty claim.

Produced in China for Nordic Season Asia Co., Ltd.